

# ABSOLUTE Digimatic Micrometers

## SERIES 227 — with Adjustable Measuring Force

### FEATURES

- Constant and low measuring force mechanism in the thimble.
- Adjustable measuring force\* accommodates various kind of work materials.  
\*0.5-2.5N or 2-10N
- The measurement-value hold function automatically retains the data at a specified measuring force, ensuring accuracy.
- Non-rotating spindle and the new ratchet friction thimble.
- Speedy spindle feed by 10mm/rev and .4"/rev for inch/metric model.
- With absolute linear scale.
- With SPC data output.
- With a standard bar to set the origin point (for models with 15 - 30mm / .6" - 1.2" range).
- Supplied in fitted plastic case.



227-201

### SPECIFICATIONS

#### Metric

Range	Resolution	Order No.	Accuracy	Measuring force
0 - 15mm	0.001mm	227-201	±2μm	0.5N - 2.5N
		227-202	±2μm	2N - 10N
15 - 30mm	0.001mm	227-203	±2μm	0.5N - 2.5N
		227-204	±2μm	2N - 10N

#### Inch/Metric

Range	Resolution	Order No.	Accuracy	Measuring force
0 - .6" / 0 - 15mm	.00005" / 0.001mm	227-211	±.0001"	0.5N - 2.5N
		227-212	±.0001"	2N - 10N
.6 - 1.2" / 15 - 30mm	.00005" / 0.001mm	227-213	±.0001"	0.5N - 2.5N
		227-214	±.0001"	2N - 10N

### DIMENSIONS AND MASS

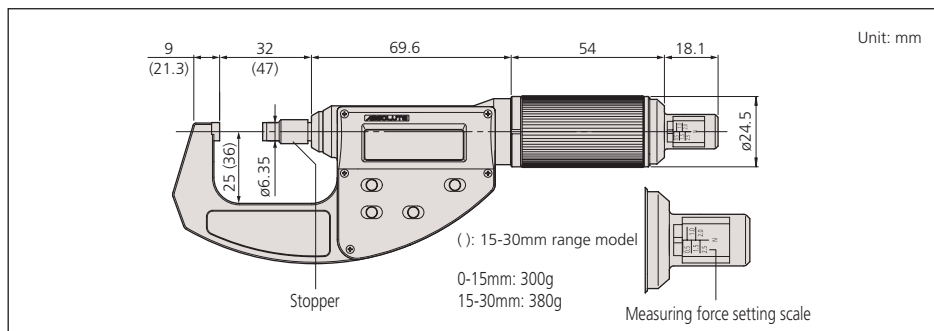

### Technical Data

Accuracy: Refer to the list of specifications.  
Resolution: 0.001mm or .00005"/0.001mm  
Flatness: 0.3μm / .000012"  
Parallelism: 2μm / .00008"  
Measuring faces: Carbide tipped  
Display: LCD  
Battery: SR44 (1 pc.), **938882**  
Battery life: Approx. 3 years under normal use  
(1 year for 15-30mm / .6 - 1.2" range model)

### Function

Origin, Hold / Data, ON/OFF, Zero / ABS,  
inch/mm conversion (on inch/metric models only)  
Alarm: Low voltage, Counting value composition error

### Optional Accessories

**937387:** SPC cable (1m / 40")  
**965013:** SPC cable (2m / 80")

