

8

7

5

4

NOTES:

- 1. ETCH IN THE APPROXIMATE SHOWN LOCATIONS.

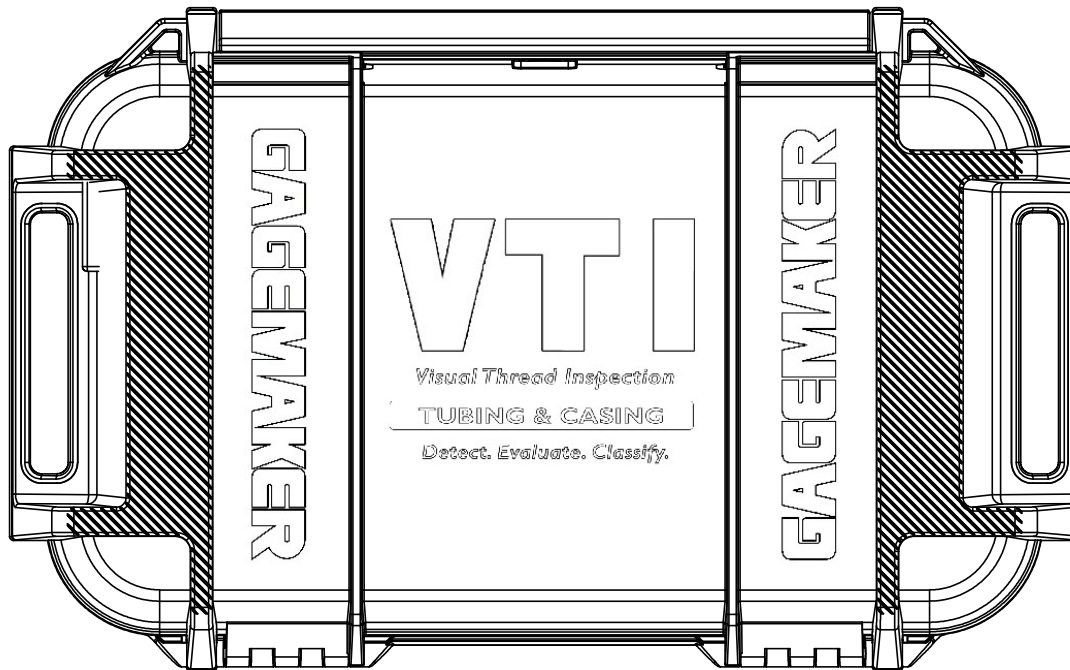
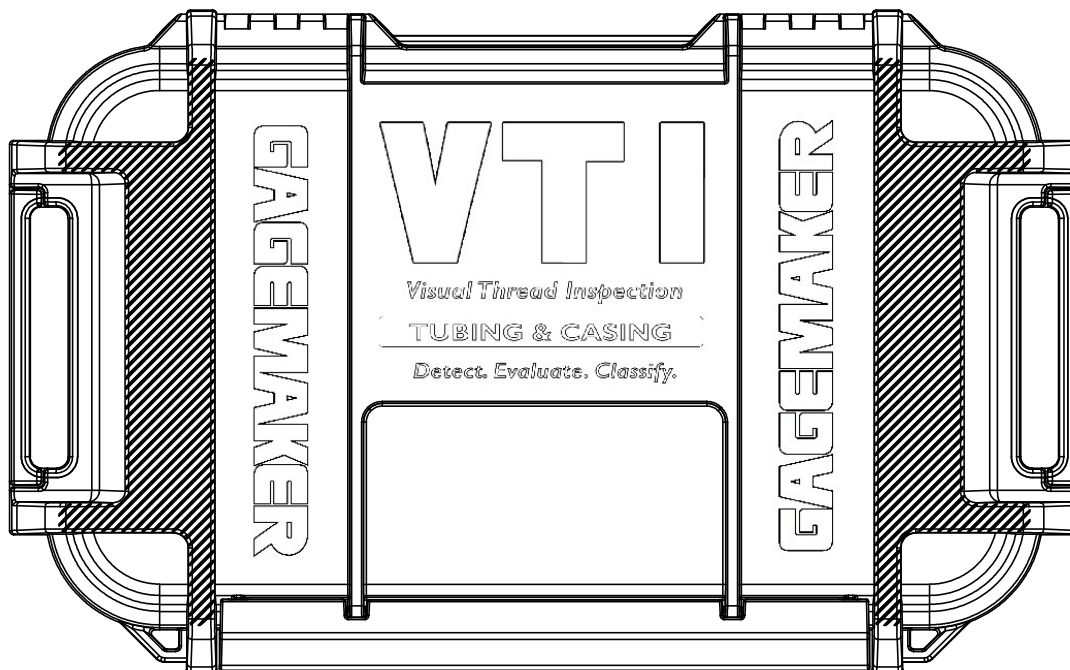

8

7

5

4

REV	DWG NUMBER	REV
C	5-5-018	
SCALE	WEIGHT	SHEET
1:1	16.94 LBS.	2 OF 3

4

3

2

1

B

B

A

A

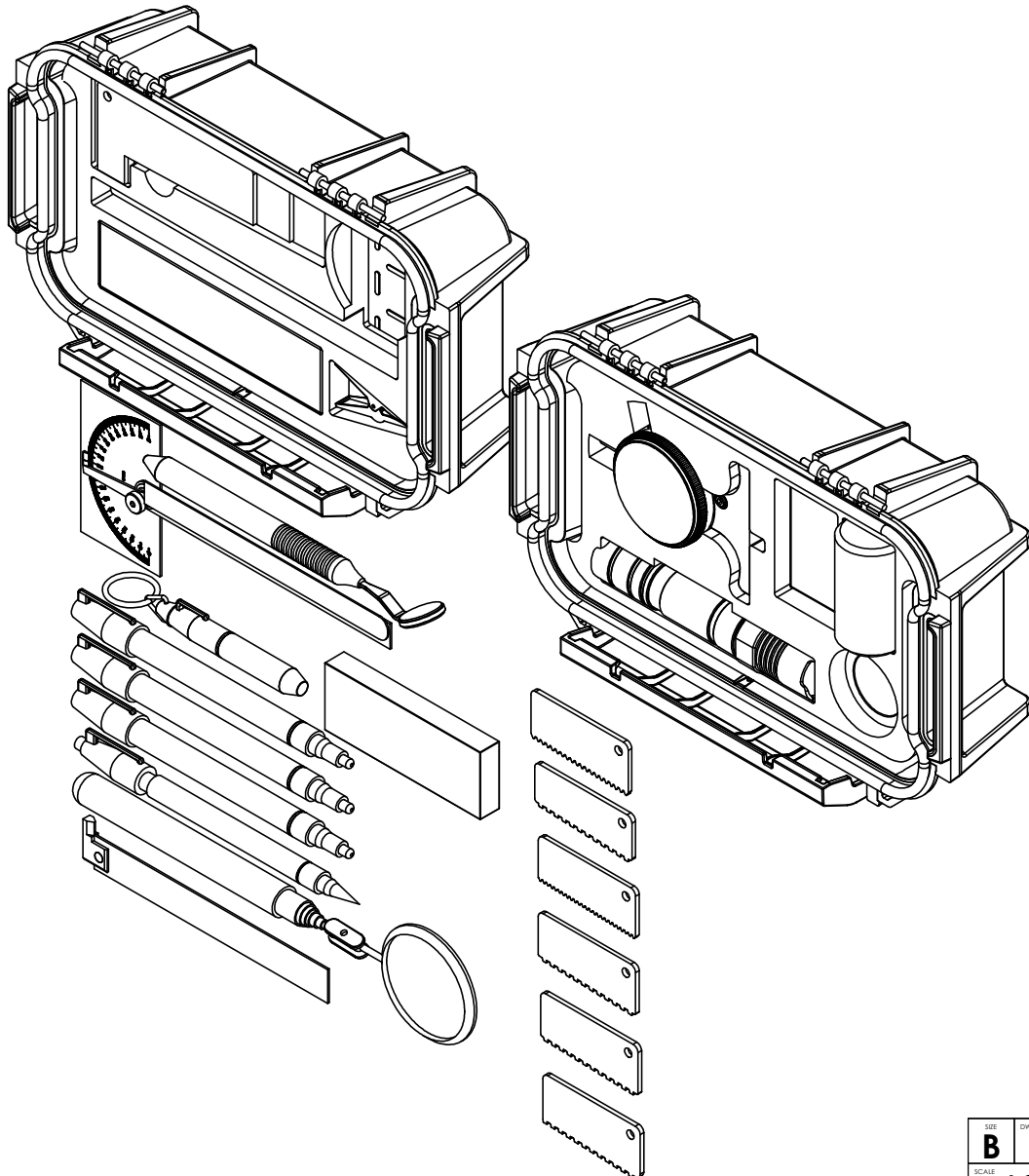

SIZE	DWG NUMBER	5-5-018	REV
B			
SCALE	1:2.2	WEIGHT	16.93 LBS.
		SHEET	3 OF 3

8

7

6

5